

PD2902

2-way 2.92mm Power Divider



The World Smallest/Lightest Coaxial Power Divider

--- 6g only

One-piece body design

IP67 protection

Without a screw



Electrical Data

Number of Output Ports	2
Frequency Range	27-29 GHz
Impedance	50 Ω
VSWR	<1.30
Insertion Loss	<0.6 dB
Isolation	>23 dB
Amplitude Balance	<0.3 dB
Phase Balance	3°
Input Power	20 W Max.
Reverse Power	0.5 W Max.

Material and Finish

Connctor(2.92mm Female)	7003 Aluminum Alloy
Housing	7003 Aluminum Alloy, Transparent Epoxy

Environmental Data

Operating Temperature	-55°C to +100°C
Storage Temperature	-55°C to +125°C
Protection Grade	IP67(Connectors Mated Condition, The Cable End 2.92mm Male Connector be Requested with A Rubber Seal Gasket)
RoHS Compliant	2011/65/EU(RoHS) and 2015/863/(RoHS)
REACH Compliant	1907/2006/EC(REACH)

Shape

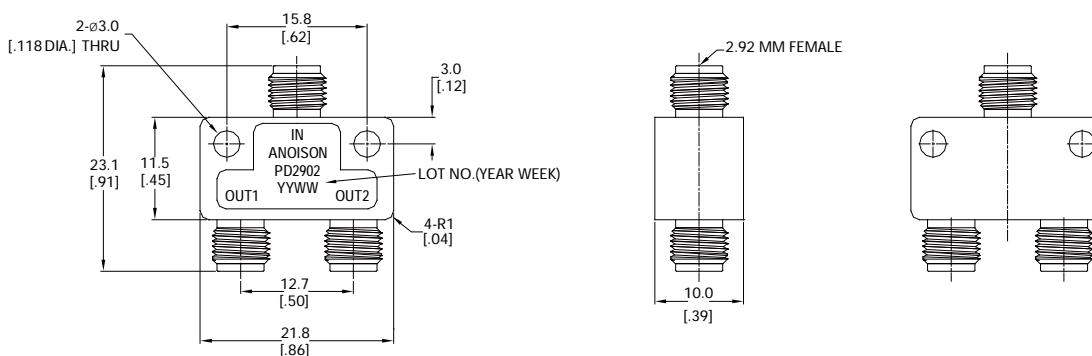

Typical Test Data

IN-OUT1

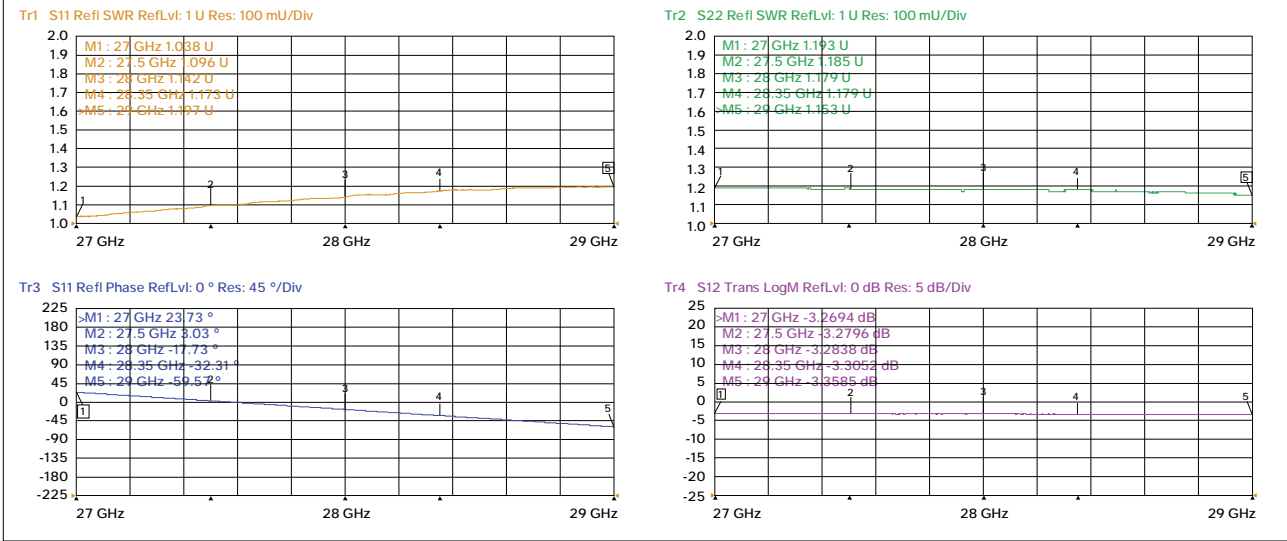

IN-OUT2

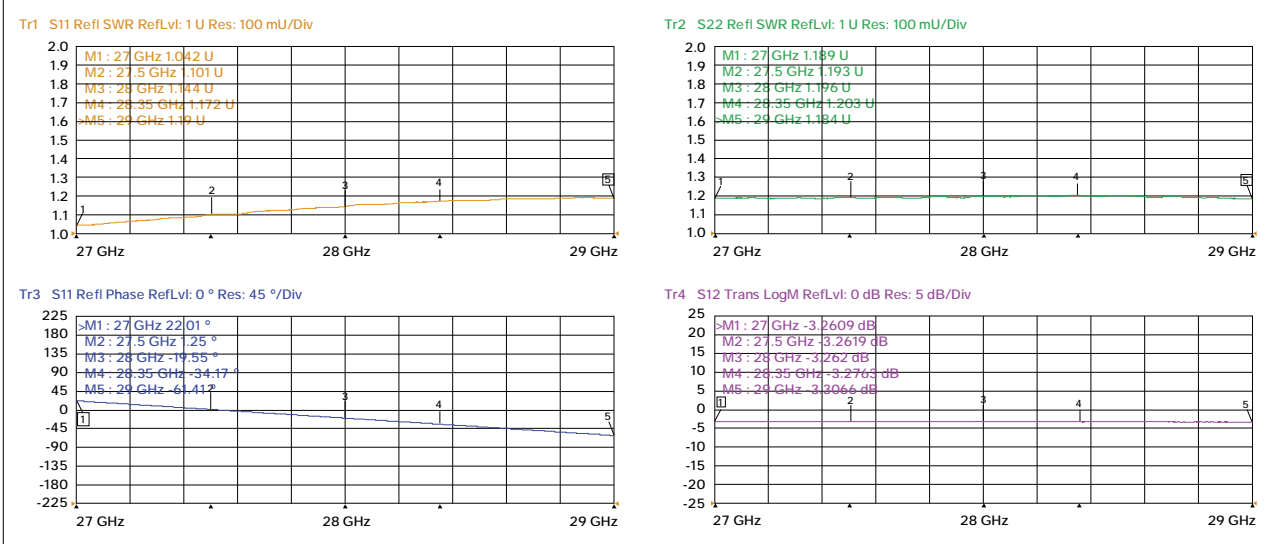

OUT1-OUT2

