

**MATERIAL & FINISH:**

- 1 BODY: STAINLESS STEEL, PASSIVATEDL
- 2 CENTER CONTACT: BERYLLIUM COPPER ALLOY, GOLD PLATED
- 3 INSULATOR: PEI
- 4 COUPLING NUT: STAINLESS STEEL, PASSIVATED

**ELECTRICAL DATA:**

- 1 IMPEDANCE: 50 Ω
- 2 FREQUENCY RANGE: DC~110 GHz

**ENVIRONMENTAL DATA:**

- 1 TEMPERATURE RANGE: -55°C~+165°C
- 2 2011/65/EU(RoHS) AND 2015/863/(RoHS): COMPLIANT
- 3 1999/45/EC(REACH): COMPLIANT

REVISIONS			
REV.	DESCRIPTION	DATE	APPROVED
A	INITIAL RELEASE	03/10/20	J. QU

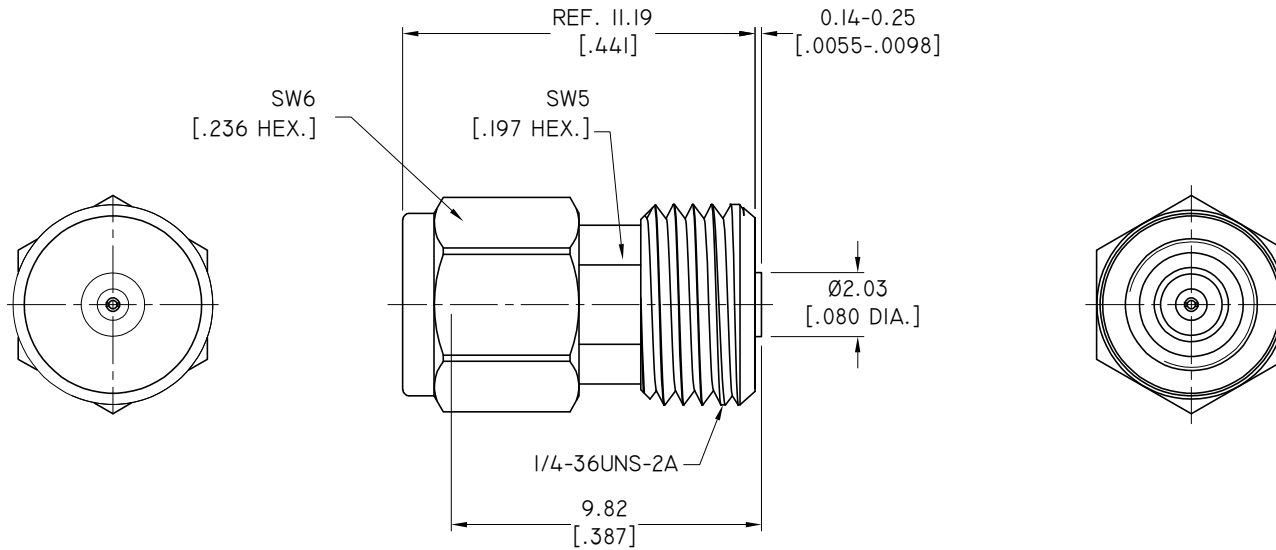

DRAWN	W. YANG	DATE	03/10/20
CHECKED	L. YANG	DATE	03/10/20
APPROVED	J. QU	DATE	03/10/20
UNLESS OTHERWISE SPECIFIED DIMENSIONS ARE IN MILLIMETERS, DIMENSIONS IN [ ] ARE IN INCHES FOR CUSTOMER REFERENCE ONLY UNLESS OTHERWISE SPECIFIED TOLERANCE ARE:		THESE DRAWINGS AND SPECIFICATIONS ARE THE PROPERTY OF ANOISON ELECTRONICS LTD AND SHOULD NOT BE USED WITHOUT WRITTEN PERMISSION COPYRIGHT © 2020 ANOISON ELECTRONICS LTD	
.XX	+0.08 [.003"]		
.X	+0.20 [.008"]		
X	+0.50 [.019"]		
.X°	±1°		
X°	±2°		



TITLE			
IMM STRAIGHT MALE, THREAD-IN (.009)			
VIEW		PART NO.	
		ANO 7611-5008	
SIZE	SCALE	SHEET	REV.
A3	5:1	1/1	A