

REVISIONS			
REV.	DESCRIPTION	DATE	APPROVED
A	INITIAL RELEASE	09/09/16	J. Q
B	FREQUENCY CHANGED	11/21/23	J. Q

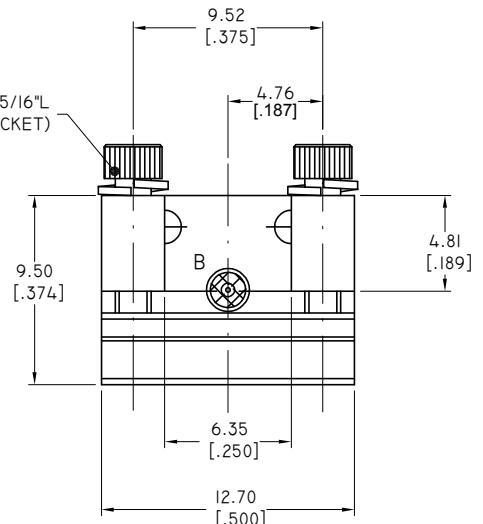
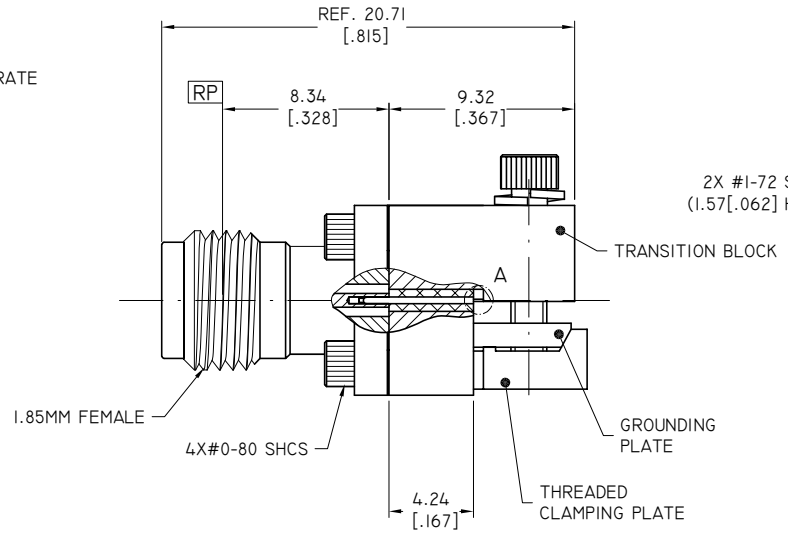
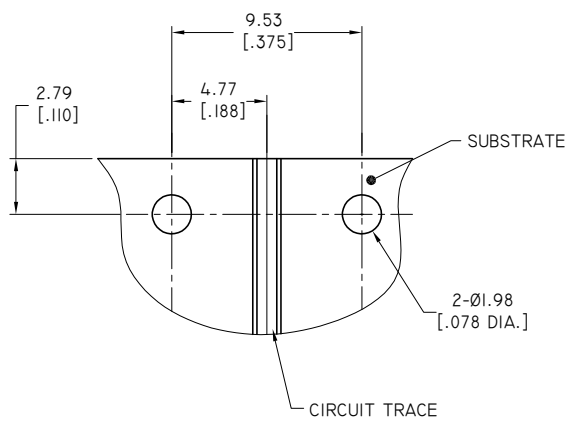

**1.85MM CONNECTOR**

1. BODY: STAINLESS STEEL, PASSIVATED
2. CENTER CONTACT: BERYLLIUM COPPER ALLOY, GOLD PLATED
3. INSULATOR: PEI

**TRANSITION BLOCK**

1. TRANSITION BLOCK: BRASS, NICKEL PLATED
2. GROUNDING PLATE: BRASS, NICKEL PLATED
3. THREADED CLAMPING PLATE: BRASS, NICKEL PLATED
4. LAUNCH PIN: BERYLLIUM COPPER ALLOY, GOLD PLATED
5. TRANSITION BLOCK DIELECTRIC: PTFE

**ENVIRONMENTAL DATA:**

1. TEMPERATURE RANGE: -55°C~+125°C
2. 2011/65/EU (RoHS): COMPLIANT

**ELECTRICAL SPECIFICATIONS:**

1. IMPEDANCE: 50 Ω
2. FREQUENCY RANGE: DC~67GHZ

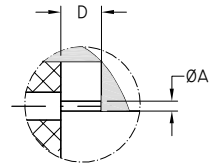

DETAIL A

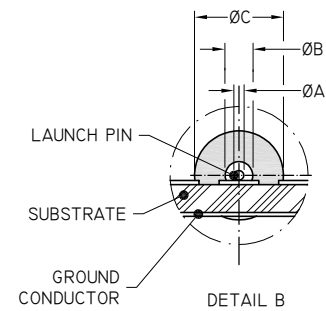

DETAIL B

PART NO.	Ø A	Ø B	Ø C	D
ANO 622-A1-H	0.18 [.007]	0.31 [.012]	0.99 [.0390]	0.76 [.030]
ANO 622-A2-H	0.13 [.005]	0.23 [.009]	0.74 [.0290]	0.76 [.030]

DRAWN	W. Y	DATE	11/21/23
CHECKED	X. Y	DATE	11/21/23
APPROVED	J. Q	DATE	11/21/23
UNLESS OTHERWISE SPECIFIED DIMENSIONS ARE IN MILLIMETERS, DIMENSIONS IN [ ] ARE IN INCHES FOR CUSTOMER REFERENCE ONLY UNLESS OTHERWISE SPECIFIED TOLERANCE ARE:		THESE DRAWINGS AND SPECIFICATIONS ARE THE PROPERTY OF ANOISON ELECTRONICS LTD AND SHOULD NOT BE USED WITHOUT WRITTEN PERMISSION COPYRIGHT © 2023 ANOISON ELECTRONICS LTD	
.XX	±0.13 [.005"]		
.X	±0.20 [.008"]		
X	±0.50 [.019"]		
X°	±1°		
X"	±2°		



TITLE  
1.85MM FEMALE END LAUNCH CONNECTOR

VIEW	PART NO. ANO 622-AX-H			
	SIZE A3	SCALE 4:1	SHEET 1/1	REV. B