

4

3

2

1

MATERIAL & FINISH:

- 1 OUTER CONTACT: BRASS, SILVER PLATED
- 2 CENTER CONTACT: BRASS, SILVER PLATED
- 3 BODY: BRASS, NICKEL PLATED
- 4 COUPLING NUT: BRASS, NICKEL PLATED
- 5 REATINING RING: PHOSPHOR BRONZE, NICKEL PLATED
- 6 INSULATOR: PTFE
- 7 GASKET: MVQ(SILICONE RUBBER)

ELECTRICAL DATA:

- 1 IMPEDANCE: 50 Ω
- 2 FREQUENCY RANGE: DC~1 GHZ
- 3 VSWR: ≤ 1.50

ENVIRONMENTAL DATA:

- 1 TEMPERATURE RANGE: -55°C~+125°C
- 2 2011/65/EU(ROHS) AND 2015/863/(ROHS): COMPLIANT
- 3 1999/45/EC(REACH): COMPLIANT

REVISIONS			
REV.	DESCRIPTION	DATE	APPROVED
A	INITIAL RELEASE	08/29/12	J. QU
B	1. 2015/863/(ROHS): COMPLIANT ADDED 2. 1999/45/EC(REACH): COMPLIANT ADDED	10/09/18	J. QU

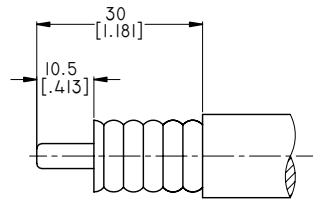
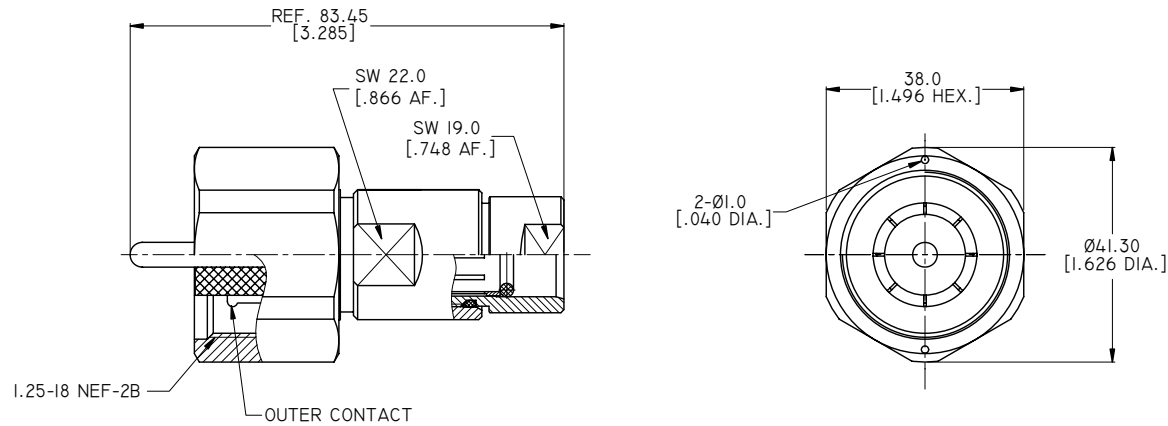

CABLE STRIPPING DIMENSIONS

DRAWN	P. CHEN	DATE	10/09/18
CHECKED	X. B. YANG	DATE	10/09/18
APPROVED	J. QU	DATE	10/09/18
UNLESS OTHERWISE SPECIFIED DIMENSIONS ARE IN MILLIMETERS, DIMENSIONS IN [] ARE IN INCHES FOR CUSTOMER REFERENCE ONLY UNLESS OTHERWISE SPECIFIED TOLERANCE ARE:		THESE DRAWINGS AND SPECIFICATIONS ARE THE PROPERTY OF ANOISON ELECTRONICS LTD AND SHOULD NOT BE USED WITHOUT WRITTEN PERMISSION COPYRIGHT © 2018 ANOISON ELECTRONICS LTD	
.XX	±0.13 [.005"]		
.X	±0.20 [.008"]		
X	±0.50 [.019"]		
.X°	±1°		
X°	±2°		



TITLE
LC MALE CONNECTOR CLAMP/NON-SOLDER CONTACT ATTACHMENT FOR 1/2 INCH ANNULAR

VIEW

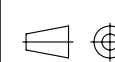

PART NO.

ANO 5811-2003

SIZE
A3SCALE
1:1SHEET
1/1REV.
B

4

3

2

1