

MATERIAL & FINISH:

- 1 BODY: STAINLESS STEEL, PASSIVATED
- 2 CENTER CONTACT: BERYLLIUM COPPER ALLO, GOLD PLATED
- 3 LOCK WASHER: STAINLESS STEEL, PASSIVATED
- 4 FASTENING NUT: STAINLESS STEEL, PASSIVATED
- 5 SOLDER FERRULE: BRASS, GOLD PLATED
- 6 INSULATOR: PTFE

ELECTRICAL DATA:

- 1 IMPEDANCE: 50 Ω
- 2 FREQUENCY RANGE: DC-12.4 GHz

ENVIRONMENTAL DATA:

- 1 TEMPERATURE RANGE: -55 °C--+125 °C
- 2 2011/65/EU(RoHS) AND 2015/863/(RoHS): COMPLIANT
- 3 1999/2006/EC(REACH): COMPLIANT

REVISIONS			
REV.	DESCRIPTION	DATE	APPROVED
A	INITIAL RELEASE	05/24/17	J. Q
B	PERFECT SPECIFICATION	03/23/23	J. Q

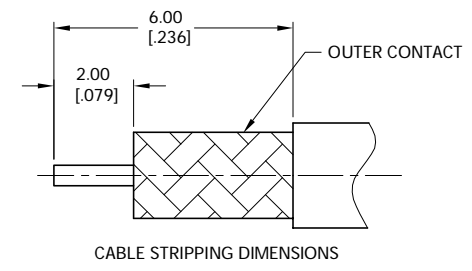
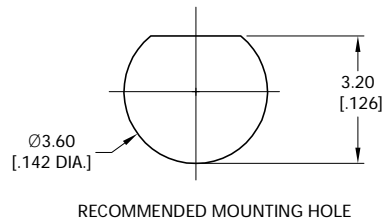
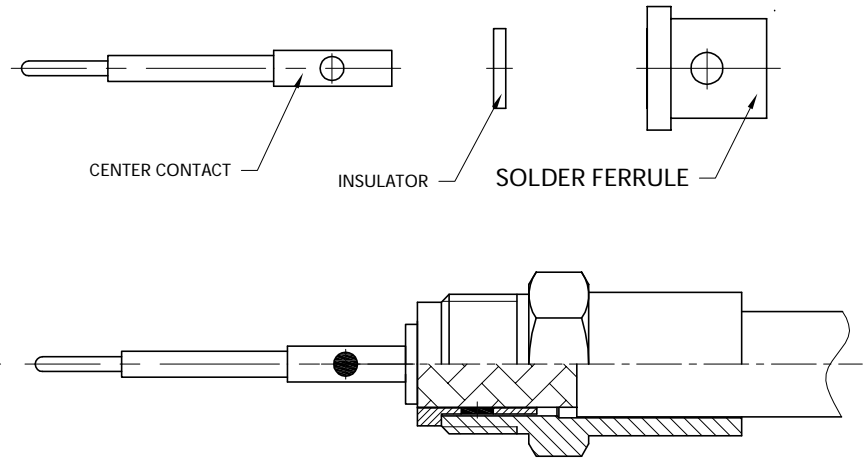
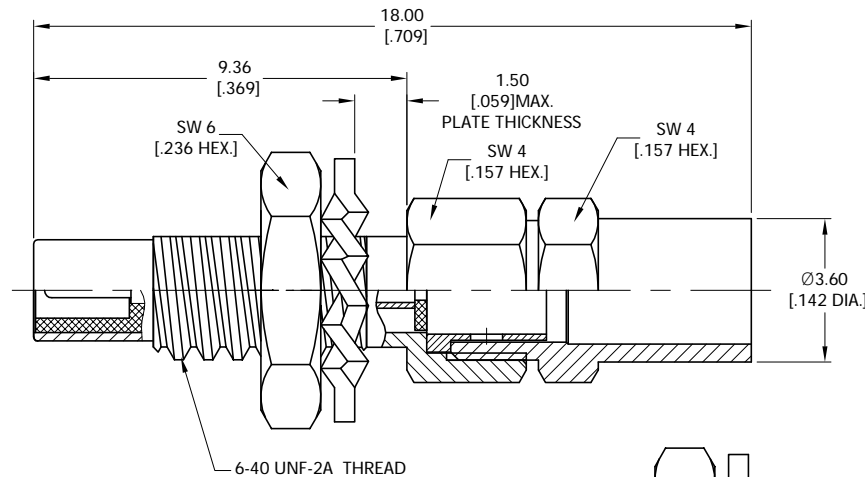

DRAWN	P. C	DATE	03/23/23
CHECKED	W. Y	DATE	03/23/23
APPROVED	J. Q	DATE	03/23/23
UNLESS OTHERWISE SPECIFIED DIMENSIONS ARE IN MILLIMETERS, DIMENSIONS IN [] ARE IN INCHES FOR CUSTOMER REFERENCE ONLY UNLESS OTHERWISE SPECIFIED TOLERANCE ARE:		THESE DRAWINGS AND SPECIFICATIONS ARE THE PROPERTY OF ANOISON ELECTRONICS LTD AND SHOULD NOT BE USED WITHOUT WRITTEN PERMISSION COPYRIGHT © 2023 ANOISON ELECTRONICS LTD	
XX	±0.13 [005"]		
X	±0.20 [008"]		
x	±0.50 [019"]		
X"	±1°		
X"	±2°		

TITLE
SSMC STRAIGHT BULKHEAD JACK MALE SOLDER FOR .086 CABLE

VIEW		PART NO. ANO 4812-2006
SIZE A3	SCALE 8:1	SHEET 1/1
REV. B		

4

3

2

1

D

C

B

A

4

3

2

1

D

C

B

A