

REVISIONS			
REV.	DESCRIPTION	DATE	APPROVED
A	INITIAL RELEASE	12/20/23	J. Q

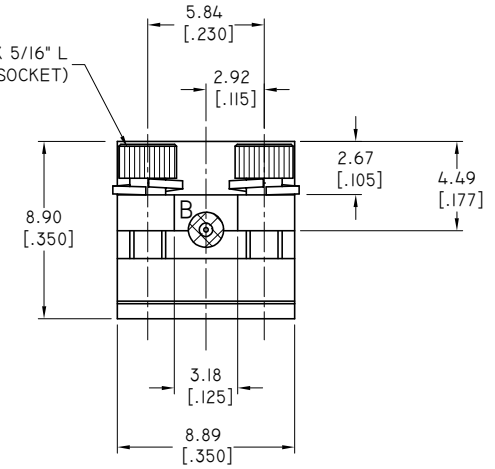
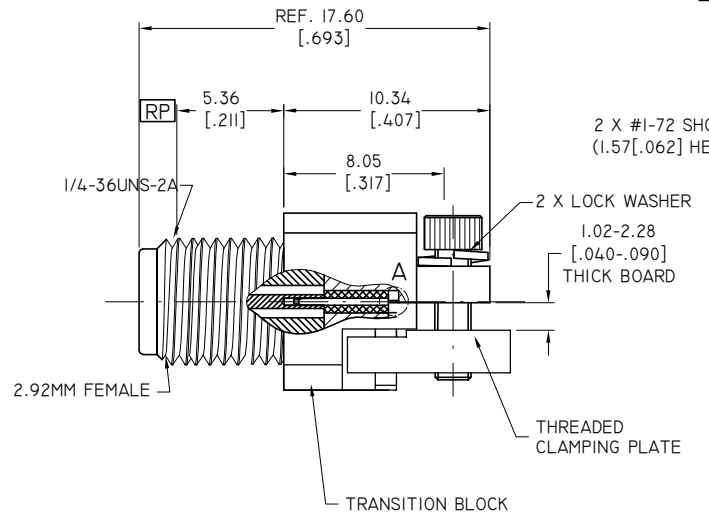
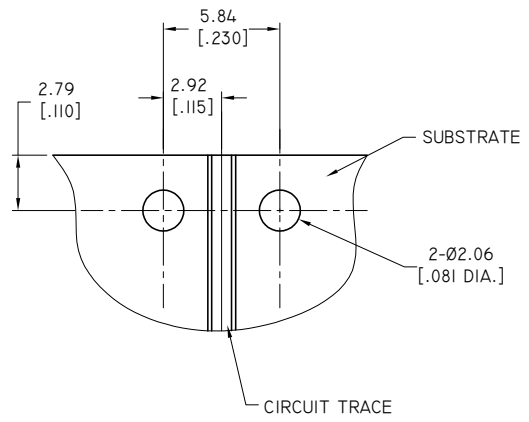

**2.92MM CONNECTOR**

1. BODY: STAINLESS STEEL, PASSIVATED
2. CENTER CONTACT: BERYLLIUM COPPER ALLOY, GOLD PLATED
3. INSULATOR: PEI

**TRANSITION BLOCK**

1. TRANSITION BLOCK: BRASS, NICKEL PLATED
2. THREADED CLAMPING PLATE: BRASS, NICKEL PLATED
3. LAUNCH PIN: BERYLLIUM COPPER ALLOY, GOLD PLATED
4. TRANSITION BLOCK DIELECTRIC: PTFE

**ENVIRONMENTAL DATA:**

1. TEMPERATURE RANGE: -55°C~+125°C
2. 2011/65/EU (RoHS): COMPLIANT

**ELECTRICAL SPECIFICATIONS:**

1. IMPEDANCE: 50 Ω
2. FREQUENCY RANGE: DC~40 GHz

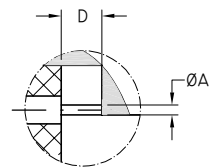

DETAIL A

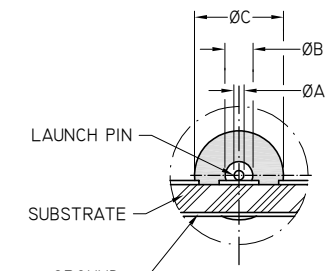

DETAIL B

PART NO.	Ø A	Ø B	Ø C	D
ANO 292-G1	0.13 [.005]	0.23 [.009]	0.74 [.0290]	0.76 [.030]
ANO 292-G2	0.18 [.007]	0.31 [.012]	0.99 [.0390]	0.76 [.030]
ANO 292-G3	0.25 [.010]	0.51 [.020]	1.61 [.0635]	1.27 [.050]

DRAWN	L. Y	DATE	12/20/23
CHECKED	W. Y	DATE	12/20/23
APPROVED	J. Q	DATE	12/20/23
UNLESS OTHERWISE SPECIFIED DIMENSIONS ARE IN MILLIMETERS, DIMENSIONS IN [ ] ARE IN INCHES FOR CUSTOMER REFERENCE ONLY UNLESS OTHERWISE SPECIFIED TOLERANCE ARE:		THESE DRAWINGS AND SPECIFICATIONS ARE THE PROPERTY OF ANOISON ELECTRONICS LTD AND SHOULD NOT BE USED WITHOUT WRITTEN PERMISSION COPYRIGHT © 2023 ANOISON ELECTRONICS LTD	
.XX	±0.13 [.005"]		
.X	±0.20 [.008"]		
X	±0.50 [.019"]		
X*	±1°		
X*	±2°		



TITLE  
2.92MM FEMALE END LAUNCH CONNECTOR  
SUPER SMALL END LAUNCH

VIEW	PART NO. ANO 292-GX			
	SIZE A3	SCALE 4:1	SHEET 1/1	REV. A