

REVISIONS			
REV.	DESCRIPTION	DATE	APPROVED
A	INITIAL RELEASE	11/03/23	J. Q

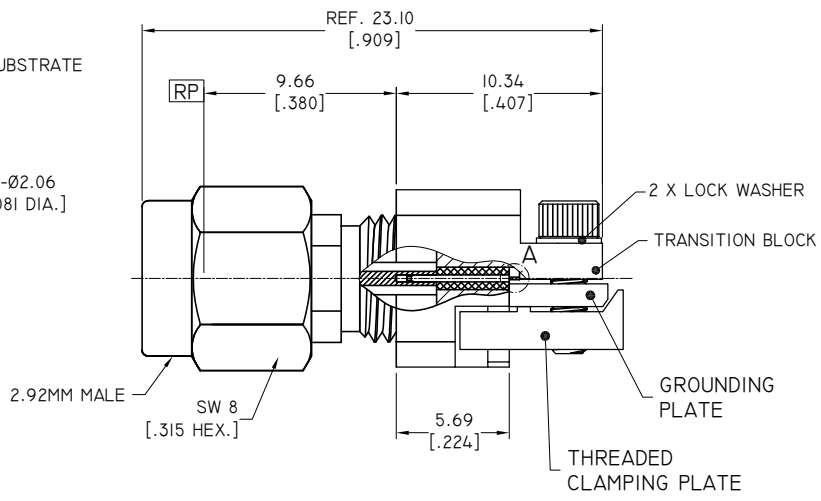

2 X #1-72 SHCS X 5/16" L
(1.57 [.062] HEX. SOCKET)

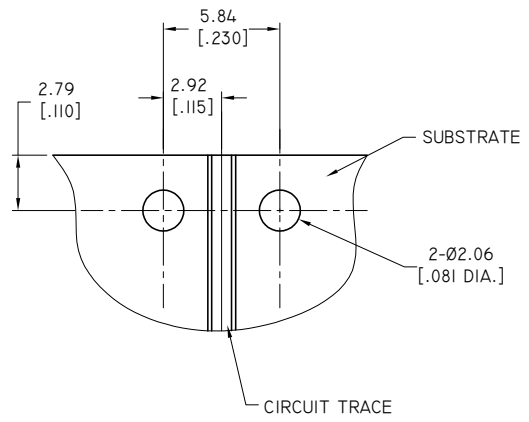
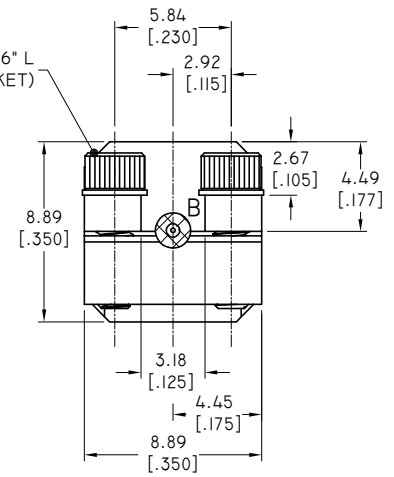

2.92MM CONNECTOR

1. BODY: STAINLESS STEEL, PASSIVATED
2. CENTER CONTACT: BERYLLIUM COPPER ALLOY, GOLD PLATED
3. INSULATOR: PEI
4. COUPLING NUT: STAINLESS STEEL, PASSIVATED
5. RETAINING RING: BERYLLIUM COPPER ALLOY, NICKEL PLATED

TRANSITION BLOCK

1. TRANSITION BLOCK: BRASS, NICKEL PLATED
2. THREADED CLAMPING PLATE: BRASS, NICKEL PLATED
3. LAUNCH PIN: BERYLLIUM COPPER ALLOY, GOLD PLATED
4. TRANSITION BLOCK DIELECTRIC: PTFE

ENVIRONMENTAL DATA:

1. TEMPERATURE RANGE: -55°C~+125°C
2. 2011/65/EU (RoHS): COMPLIANT

ELECTRICAL SPECIFICATIONS:

1. IMPEDANCE: 50 Ω
2. FREQUENCY RANGE: DC~40 GHz

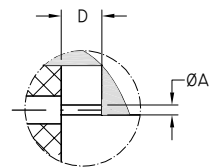

DETAIL A

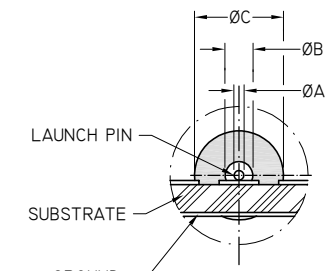

DETAIL B

PART NO.	Ø A	Ø B	Ø C	D
ANO 291-E1	0.13 [.005]	0.23 [.009]	0.74 [.0290]	0.76 [.030]
ANO 291-E2	0.18 [.007]	0.31 [.012]	0.99 [.0390]	0.76 [.030]
ANO 291-E3	0.25 [.010]	0.51 [.020]	1.61 [.0635]	1.27 [.050]

DRAWN	W. Y	DATE	11/03/23
CHECKED	X. Y	DATE	11/03/23
APPROVED	J. Q	DATE	11/03/23
UNLESS OTHERWISE SPECIFIED DIMENSIONS ARE IN MILLIMETERS, DIMENSIONS IN [] ARE IN INCHES FOR CUSTOMER REFERENCE ONLY UNLESS OTHERWISE SPECIFIED TOLERANCE ARE:		THESE DRAWINGS AND SPECIFICATIONS ARE THE PROPERTY OF ANOISON ELECTRONICS LTD AND SHOULD NOT BE USED WITHOUT WRITTEN PERMISSION COPYRIGHT © 2023 ANOISON ELECTRONICS LTD	
.XX	±0.13 [.005"]		
.X	±0.20 [.008"]		
.X*	±0.50 [.019"]		
X*	±1"		
X*	±2"		

ANOISON

TITLE: 2.92MM MALE END LAUNCH CONNECTOR THD-IN SUPER SMALL

VIEW:

PART NO. ANO 291-EX

SIZE	SCALE	SHEET	REV.
A3	4:1	1/1	A