

# ***N Connectors Series***



<b>Content.....</b>	<b>Page</b>
Description .....	2
Interface Dimensions .....	2
Interface Dimensions in mm/inches .....	2
Characteristics .....	3
Cable Connectors .....	4
PCB Connectors .....	8
Panel Receptacles .....	9
Adapter Connectors .....	13
Termination .....	19
Assembly Instruction .....	20

## Description

The Type N connector was developed in the 1940's to satisfy the need for a durable, weatherproof, medium-size RF connector with consistent performance through 11 GHz. N series connector has been a staple in RF and Microwave applications all over the world. It is suited to a vast range of applications from military and aerospace to wireless LAN.

## Interface Dimensions

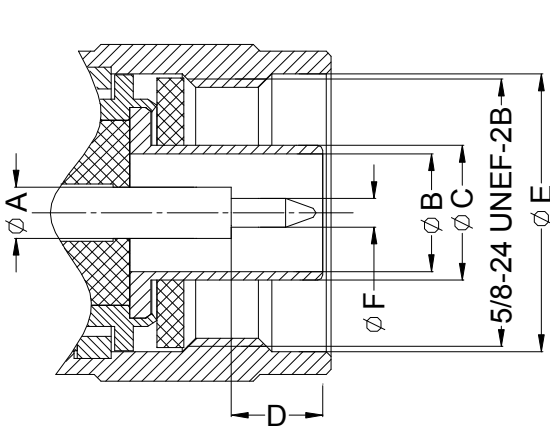

Plug (male)

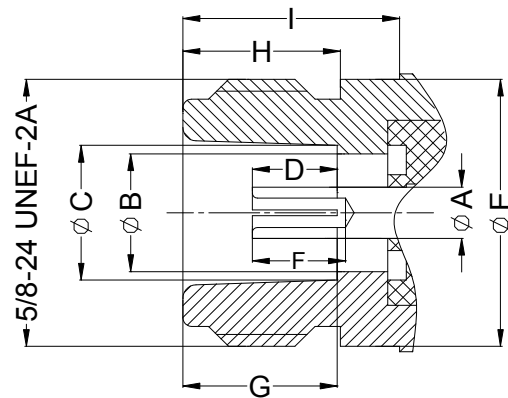

Jack (female)

## Interface Dimensions (mm/inches)

	Plug		Jack	
	min.	max.	min.	max.
A	-	3.06/.120	-	3.15/.124
B	6.98/.275	7.02/.276	-	7.06/.278
C	-	8.00/.315	8.03/.316	8.13/.320
D	5.33/.210	5.84/.230	4.75/.187	5.26/.207
E	16.00/.630	-	-	15.93/.627
F	1.60/.063	1.68/.066	5.33/.210	-
G	-	-	9.04/.356	9.19/.362
H	-	-	6.76/.266	-
I	-	-	10.72/.422	-

### Interface dimensions conformable to the standards:

International: **IEC 61169-16**  
 Europe: **CECC 22 210**  
 USA: **MIL-STD-348A/304**

## Characteristics

ELECTRICAL	REQUIREMENTS
Impedance	50
Frequency range	DC to 18 GHz
Dielectric Withstanding Voltage	2500 V rms 50 Hz, sea level
Working Voltage	≤1,000 V rms 50 Hz, sea level
VSWR	Straight connector, .141": ≤1.29 (DC~11GHZ)
	Straight connector, RG316: ≤1.21 (DC~6GHZ)
	Right angle connector, .141": ≤1.38 (DC~11GHZ)
	Right angle connector, RG316: ≤1.30 (DC~6GHZ)
Insulation Resistance	5×10 <sup>3</sup> MΩ min.(initial)
Contact Resistance	
- Center contact	1.0 m max..
- Outer contact	1.0 m max.
RF-leakage	
DC to 3 GHz	-90 dB min.
3 GHz to 6 GHz	-75 dB min.

MECHANICAL	REQUIREMENTS
Coupling Nut Torque	
- Recommended	0.68 Nm~1.13 Nm / 6.0~10.0 in. lbs
- Proof torque	1.70 Nm /15.0 in. lbs
Coupling Nut Retention Force	≥450 N /101.2 lbs
Contact Captivation	≥ 28 N/6.3 lbs
Cable Retention Force	
- cable 5/50	150 N/33.75 lbs (single braid) 200 N/48 lbs (double braid)
-cable 10.5/50	300 N/67.5 lbs
-cable 11/50	400 N/90 lbs
-cable .141	270 N/60.75 lbs
Durability ( Mating Cycles)	500 min.

ENVIRONMENTAL	REQUIREMENTS
Temperature Range	-55°C to +155°C
Climactic Category	IEC→55/155/21
Corrosion	Salt spray test acc. to MIL-STD-202, Method 101, Condition B
Moisture Resistance	MIL-STD-202 F, Method 106 F
Vibration	IEC-1169-1 Paragraph9.3.3(10-500 Hz;5g)
Shock	MIL-STD-202, Method 213, Condition I

**Note:** The above characteristics are typical but may not apply to all connectors.

## Cable Connectors

### Straight Cable Plugs (male)

#### >for semi-rigid cables

Part No.	Cable Group (Example)	Finish	Remarks	Assembly Instruction
ANO 5111-2034	.141/50 (SMT680-141/RG402)	Passivated	Solder	AI 01

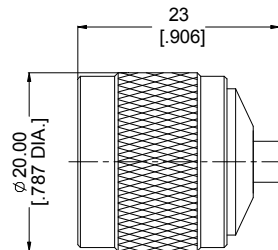

#### >for flexible cables

Part No.	Cable Group (Example)	Finish	Remarks	Assembly Instruction
ANO 5111-2039	2/50/S (R678)	Nickel	Solder	AI 02

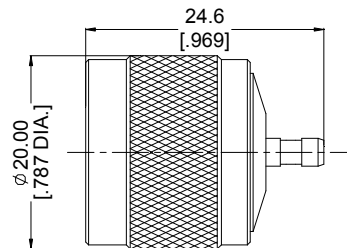

#### >for flexible cables

Part No.	Cable Group (Example)	Finish	Remarks	Assembly Instruction
ANO 5111-2006	2.6/50/S/D (RG316/LMR100)	Nickel	Crimp	AI 03

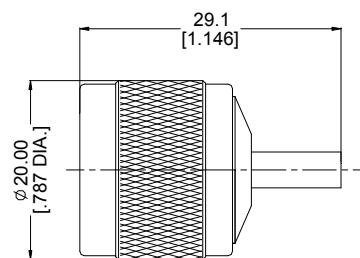

#### >for flexible cables

Part No.	Cable Group (Example)	Finish	Remarks	Assembly Instruction
ANO 5111-2007	5/50/S/D (R68/LMR195)	Nickel	Crimp	AI 03
ANO 5111-2002	5/50/S/D (R68/LMR200)	Nickel	Crimp	AI 03

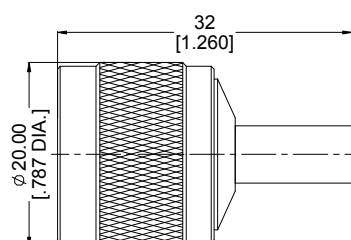

### >for flexible cables

Part No.	Cable Group (Example)	Finish	Remarks	Assembly Instruction
ANO 5111-2003	6/50 /D (LMR240)	Nickel	Crimp	AI 03

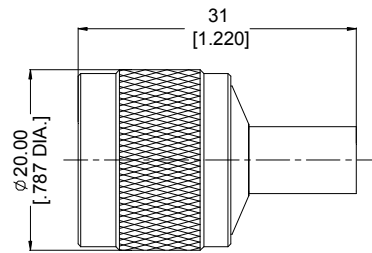

### >for flexible cables

Part No.	Cable Group (Example)	Finish	Remarks	Assembly Instruction
ANO 5111-2037	7.5/50 /D (LMR300)	Nickel	Crimp	AI 03

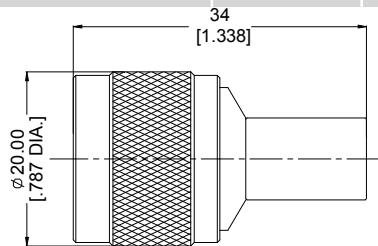

### >for flexible cables

Part No.	Cable Group (Example)	Finish	Remarks	Assembly Instruction
ANO 5111-2001	10.5/50 /D (LMR400)	Nickel	Crimp	AI 03

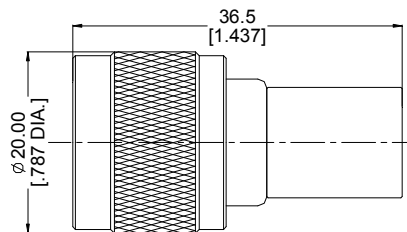

### >for flexible cables

Part No.	Cable Group (Example)	Finish	Remarks	Assembly Instruction
ANO 5111-2028	15/50 /D (LMR600)	Nickel	Crimp	AI 03

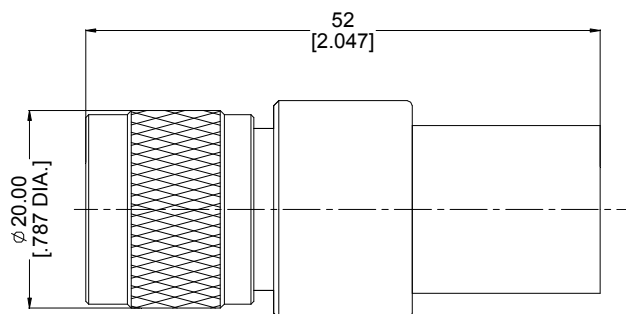

## Right Angle Cable Plugs (male)

>for flexible cables

Part No.	Cable Group (Example)	Finish	Remarks	Assembly Instruction
ANO 5121-2041	7.5/50 /D (LMR300)	Nickel	Crimp	AI 05

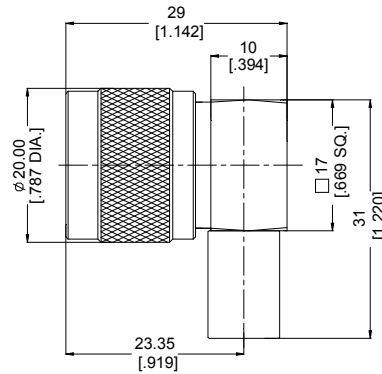

>for flexible cables

Part No.	Cable Group (Example)	Finish	Remarks	Assembly Instruction
ANO 5121-2040	10.5/50 /D (LMR400)	Nickel	Clamp	AI 06

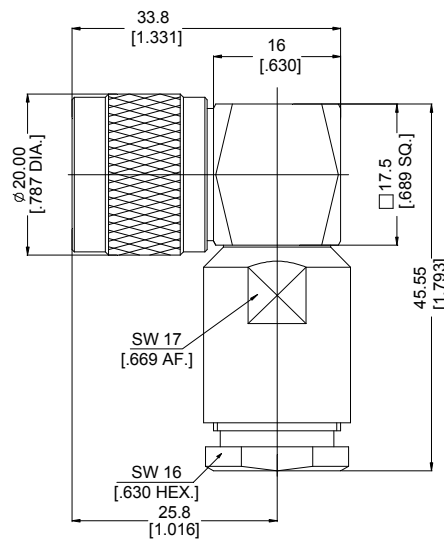

## Straight Cable Jacks (female)

>for flexible cables

Part No.	Cable Group (Example)	Finish	Remarks	Assembly Instruction
ANO 5112-2038	7.5/50 /D (LMR300)	Nickel	Crimp	AI 04

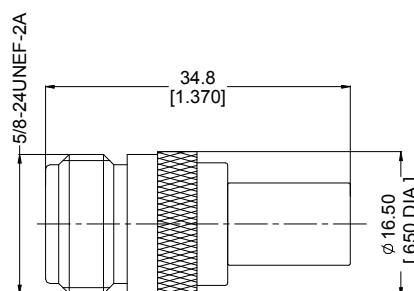

### >for flexible cables

Part No.	Cable Group (Example)	Finish	Remarks	Assembly Instruction
ANO 5112-2025	10.5/50 /D (LMR400)	Nickel	Crimp	AI 04

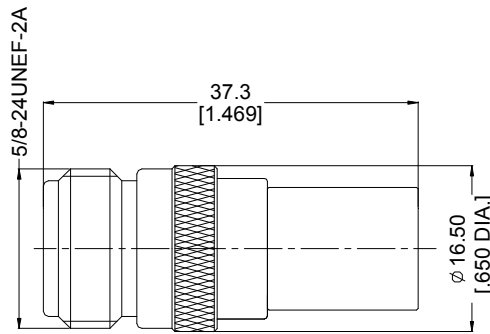

### Straight Bulkhead Cable Jacks (female)

### >for semi-rigid cables

Part No.	Cable Group (Example)	Finish	Remarks	Assembly Instruction / Mounting Hole	Fig.
ANO 5112-1018	.083/.085/50 (SMT680-086/RG405)	Nickel	Solder	AI 01/MH 5	1
ANO 5112-1024	.083/.085/50 (SMT680-086/RG405)	Nickel	Solder	AI 01/MH 5	2

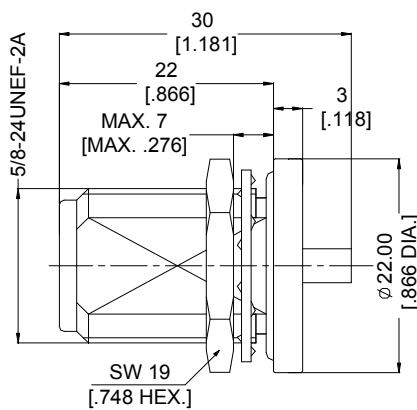

**Fig.1**

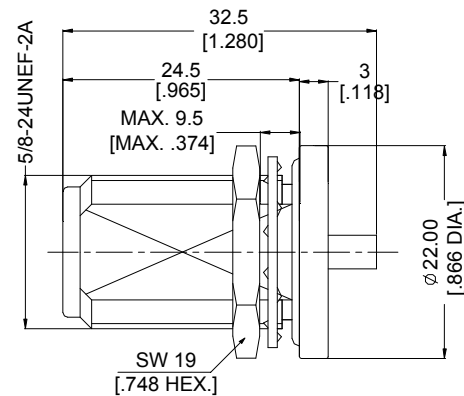

**Fig.2**

### >for flexible cables

Part No.	Cable Group (Example)	Finish	Remarks	Assembly Instruction / Mounting Hole
ANO 5112-1008	2/50/S (RG78)	Nickel	Solder	AI 07/MH 5

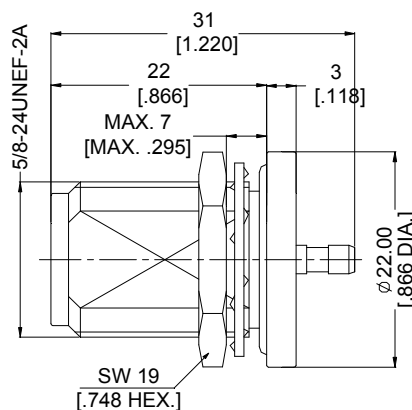

## >for flexible cables

Part No.	Cable Group (Example)	Finish	Remarks	Assembly Instruction/Mounting Hole
ANO 5112-1010	2.6/50/S/D (RG316/LMR100)	Nickel	Crimp	AI 08/MH 5

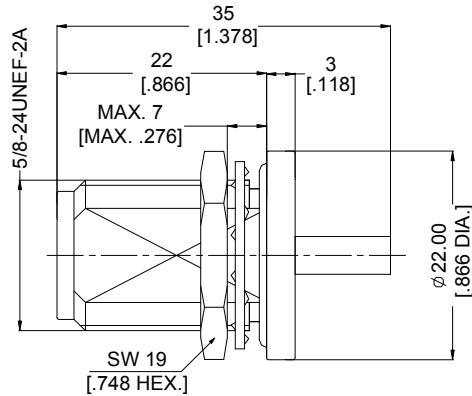

## >for flexible cables

Part No.	Cable Group (Example)	Finish	Remarks	Assembly Instruction/Mounting Hole
ANO 5112-1009	5/50/S/D (R58/LMR195)	Nickel	Crimp	AI 08/MH 5

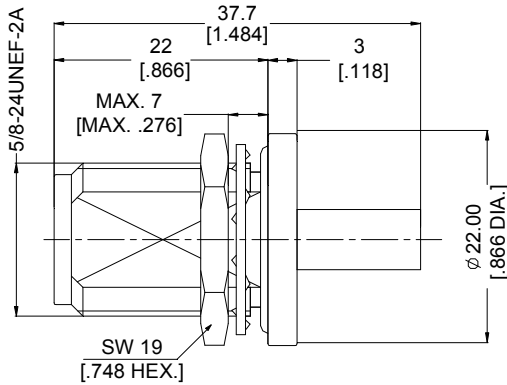

## PCB Connectors

### Straight PCB jacks (female)

Part No.	Finish	PCB Pattern
ANO 5111-5031	Nickel	MH 13

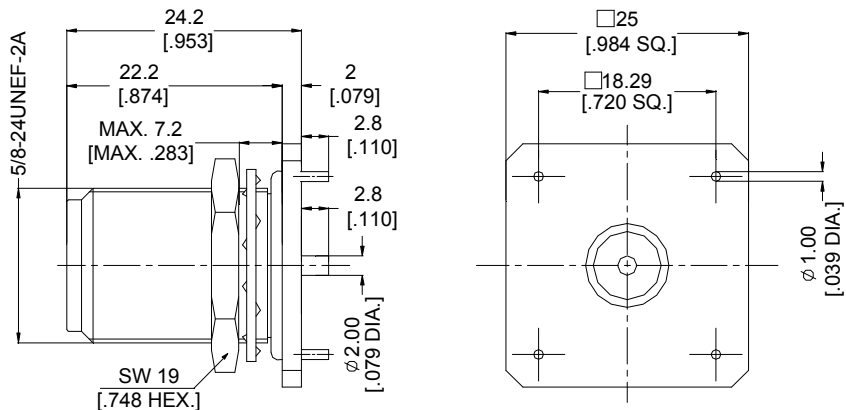



## Right Angle PCB jacks (female)

Part No.	Finish	PCB Pattern
ANO 5122-4026	Nickel	MH 18

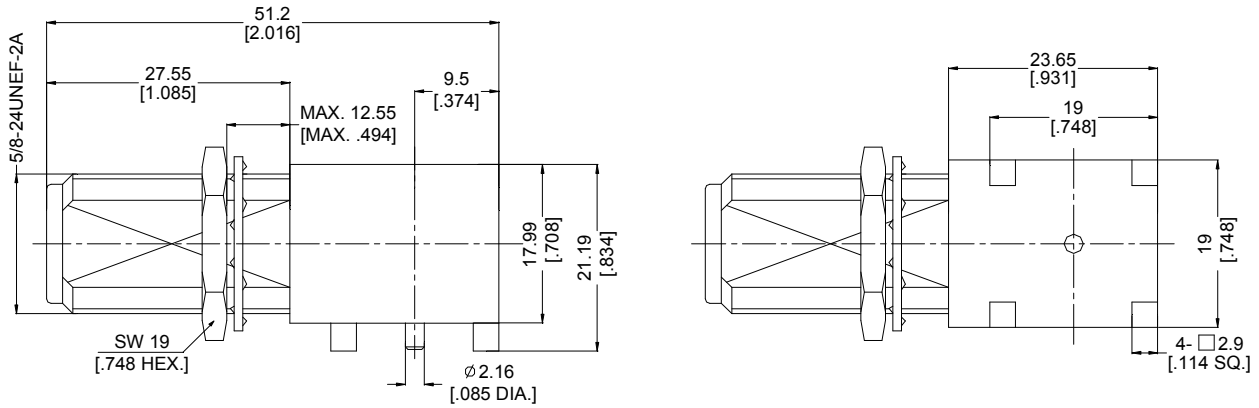

## Panel Receptacles

### Receptacles, plugs (male)

Part No.	Finish	Mounting Hole
ANO 5111-3004	Nickel	MH 8

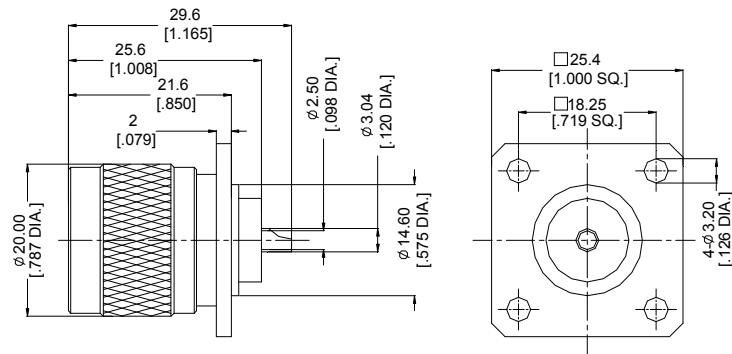

### Receptacles, jack (female)

Part No.	Finish	Mounting Hole
ANO 5112-5013	Nickel	MH 5

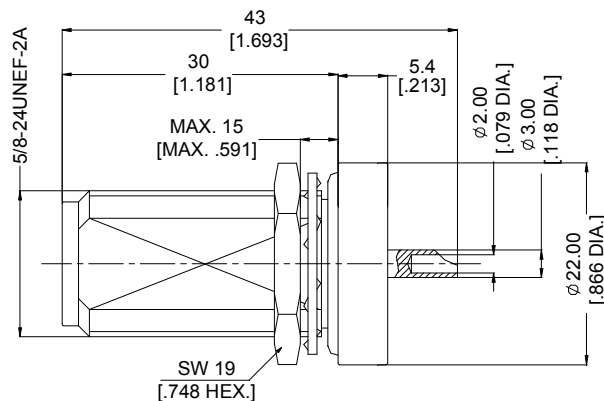

## Receptacles, jack (female)

Part No.	Finish	Mounting Hole
ANO 5112-1042	Nickel	MH 5

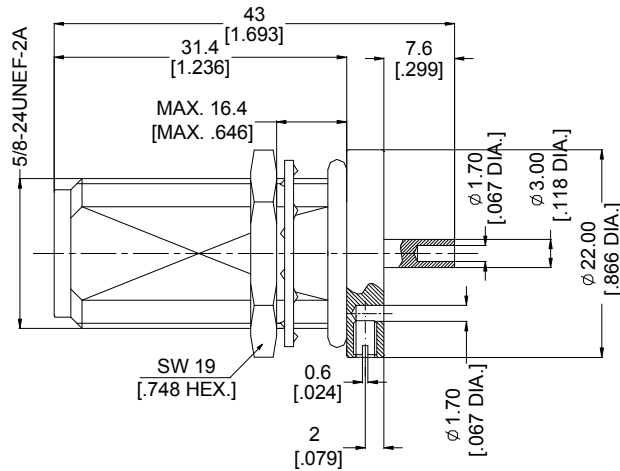

## Receptacles, jack (female)

Part No.	Finish	Mounting Hole
ANO 5112-3011	Nickel	MH 7

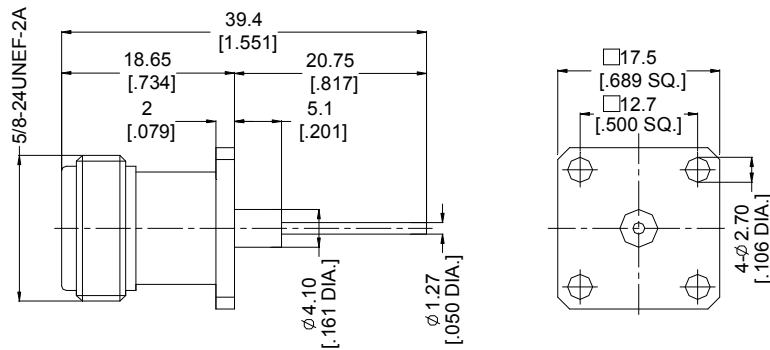

## Receptacles, jack (female)

Part No.	Finish	Mounting Hole
ANO 5112-3012	Nickel	MH 12

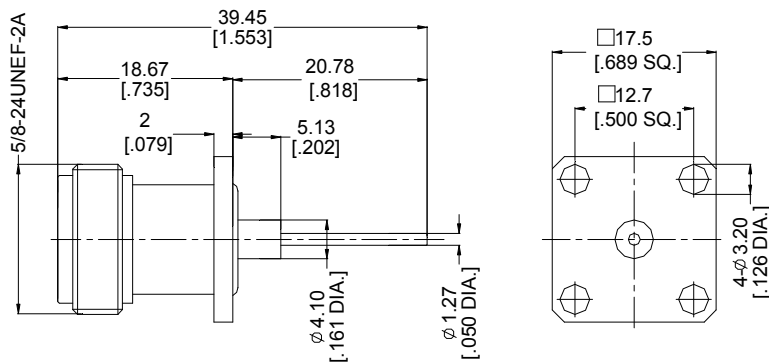

## Receptacles, jack (female)

Part No.	Finish	Mounting Hole
ANO 5112-3014	Nickel	MH 12

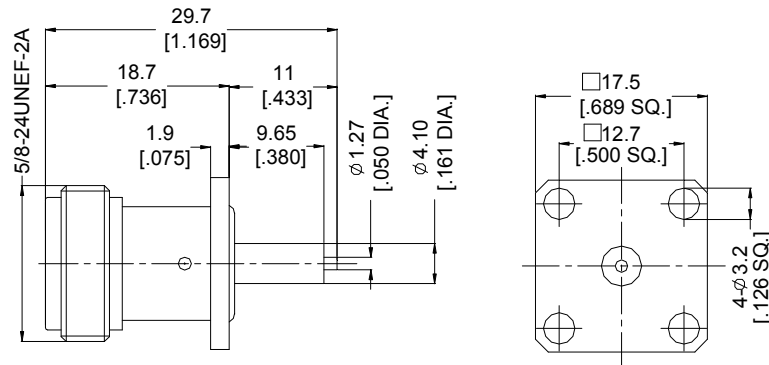

## Receptacles, jack (female)

Part No.	Finish	Mounting Hole
ANO 5113-3016	Nickel	MH 6

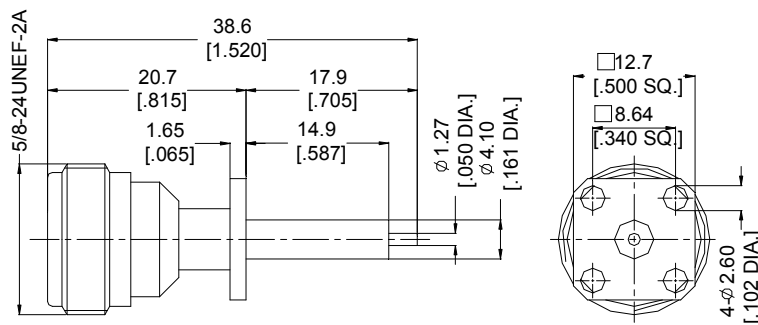

## Receptacles, jack (female)

Part No.	Finish	Mounting Hole
ANO 5112-3022	Nickel	MH 6

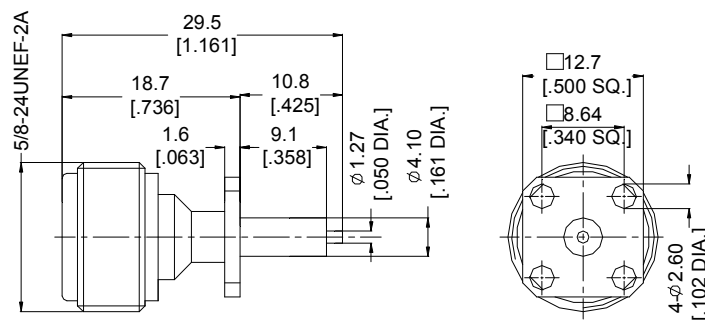

## Receptacles, jack (female)

Part No.	Finish	Mounting Hole
ANO 5112-3023	Nickel	MH 8
ANO 5112-3035	Albaloy	MH 8

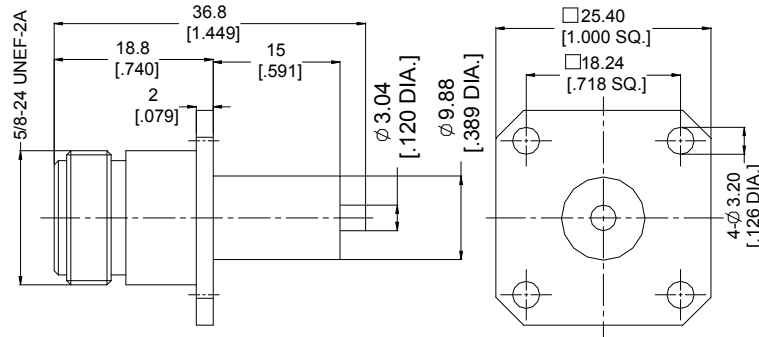

## Flat tab receptacles, jack (female)

Part No.	Finish	Dimensions	Mounting Hole
ANO 5112-3015	Nickel	A=0.25/.010	MH 12
ANO 5112-3020	Nickel	A=0.13/.005	MH 12

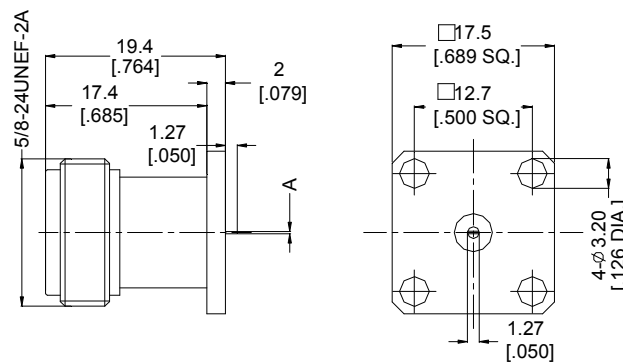

## Slot receptacles, jack (female)

Part No.	Finish	Mounting Hole
ANO 5112-3021	Nickel	MH 8

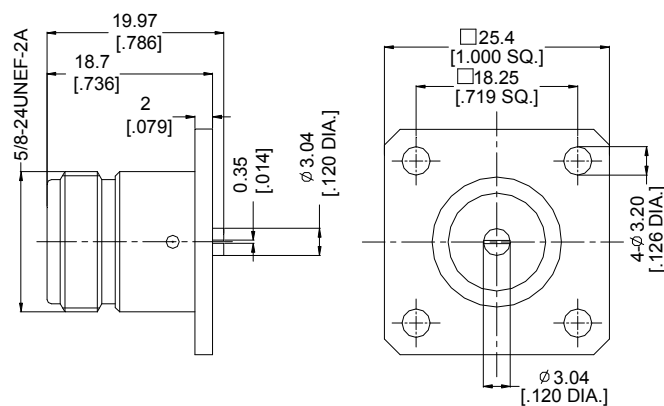

## Adapter Connectors

### Adapter plug/plug (male/male)

Part No.	Finish	Type / Type
ANO 511-511-1009	Nickel	N(plug) / N(plug)

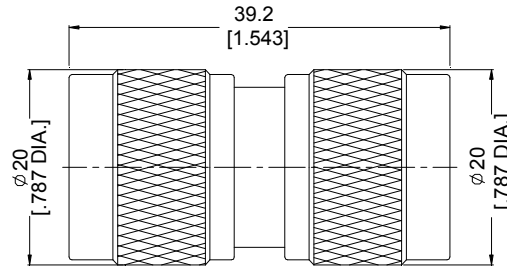

### Adapter plug/plug (male/male)

Part No.	Finish	Type / Type
ANO 511-333-1017	Nickel	N(plug) / RP TNC(plug)

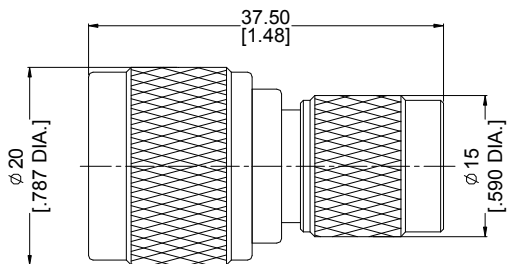

### Adapter plug/plug (male/male)

Part No.	Finish	Type / Type
ANO 511-261-1033	Nickel	N(plug) / QMA(plug)

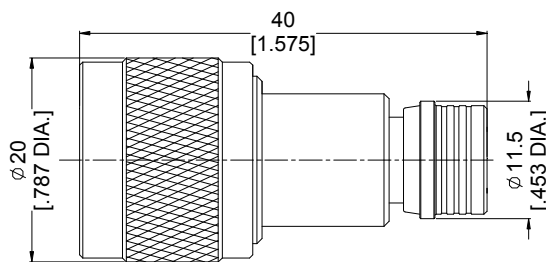

### Adapter plug/plug (male/male)

Part No.	Finish	Type / Type
ANO 511-281-1055	Nickel	N(plug) / Mini-QMA(plug)

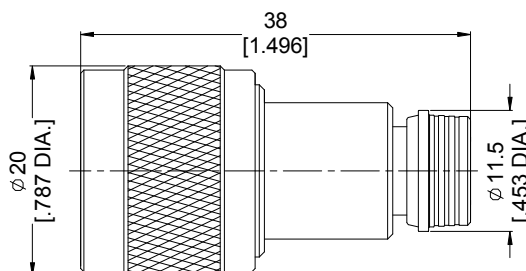

## Adapter plug/plug (male/male)

Part No.	Finish	Type / Type
ANO 511-531-1044	Nickel	N(plug) /HPQN(plug)

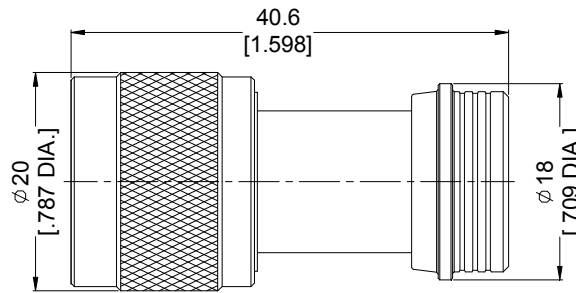

## Bulkhead Adapter jack/jack (female/female)

Part No.	Finish	Type / Type	Mounting Hole
ANO 512-512-1022	Nickel	N(jack) /N(jack)	MH 5

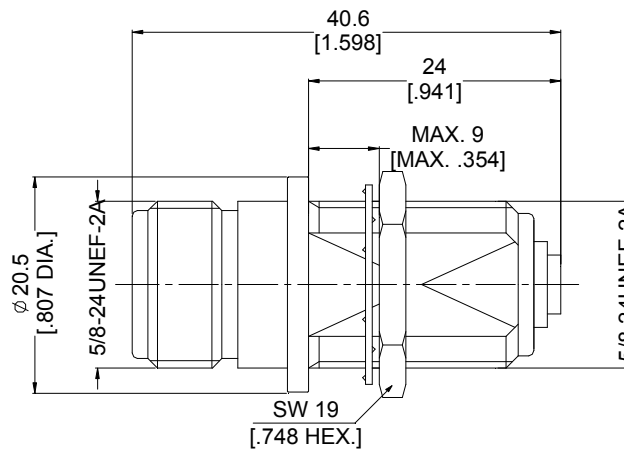

## Bulkhead Adapter jack/jack (female/female)

Part No.	Finish	Type / Type	Mounting Hole
ANO 512-512-1018	Nickel	N(jack) /N(jack)	MH 5

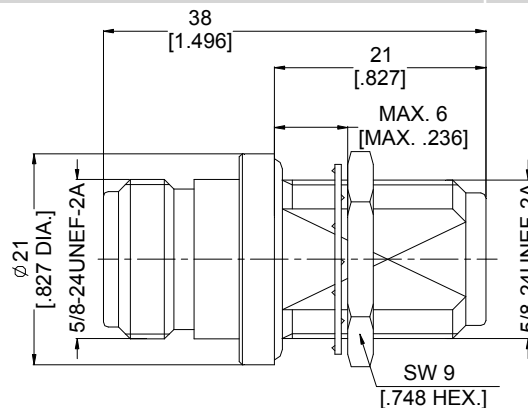

### Adapter jack/jack (female/female)

Part No.	Finish	Type / Type
ANO 515-334-1015	Nickel	N(jack) /RP-TNC(jack)

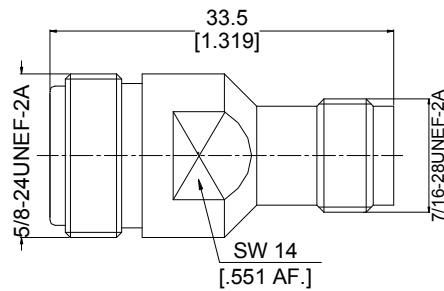

### Adapter jack/jack (female/female)

Part No.	Finish	Type / Type
ANO 512-212-1025	Nickel	N(jack) /SMA(jack)

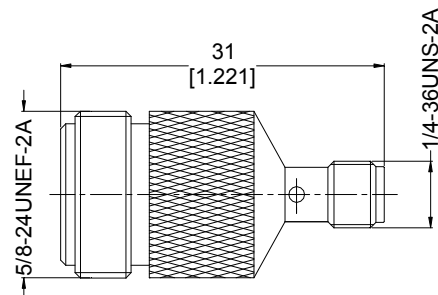

### Adapter jack/jack (female/female)

Part No.	Finish	Type / Type
ANO 512-262-1034	Nickel	N(jack) /QMA(jack)

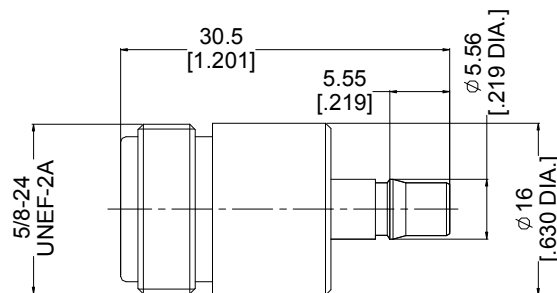

### Adapter jack/jack (female/female)

Part No.	Finish	Type / Type
ANO 512-282-1056	Nickel	N(jack) /Mini-QMA(jack)

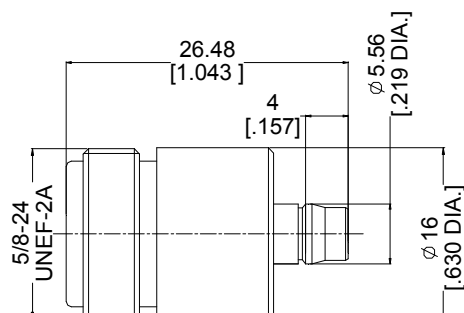

## Adapter jack/jack (female/female)

Part No.	Finish	Type / Type
ANO 512-532-1045	Nickel	N(jack) /HPQN(jack)

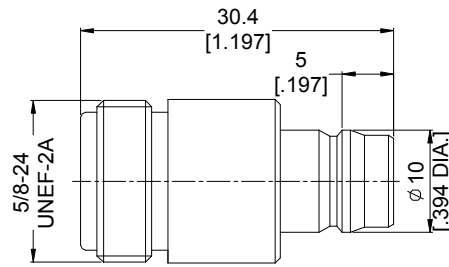

## Adapter plug/jack (male/female)

Part No.	Finish	Type / Type
ANO 512-971-1012	Tin	N(jack) /F(plug)

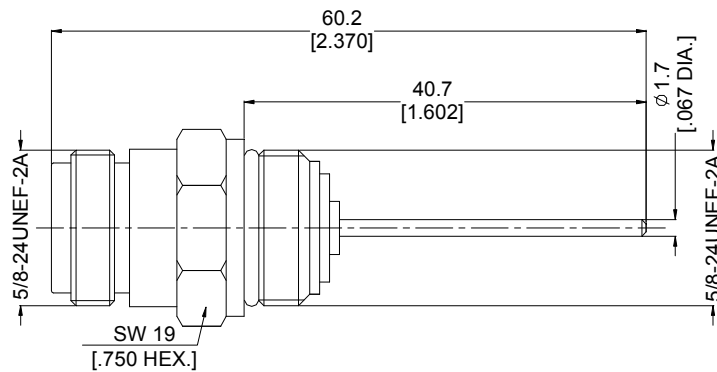

## Adapter plug/jack (male/female)

Part No.	Finish	Type / Type
ANO 511-214-1010	Nickel	N(plug) /RP-SMA(jack)
ANO 511-212-1024	Nickel	N(plug) / SMA(jack)

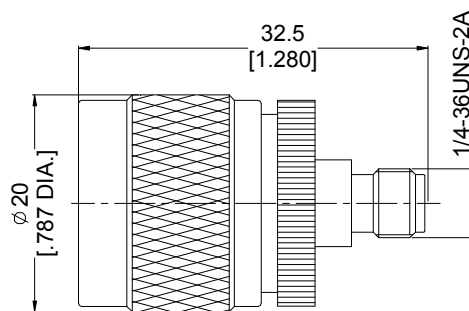



### Adapter plug/jack (male/female)

Part No.	Finish	Type / Type
ANO 511-332-1016	Nickel	N(plug) / TNC(jack)

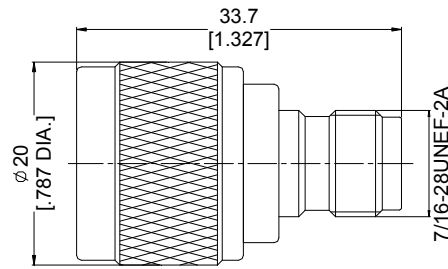

### Adapter plug/jack (male/female)

Part No.	Finish	Type / Type
ANO 512-331-1011	Nickel	N(jack) / TNC(plug)

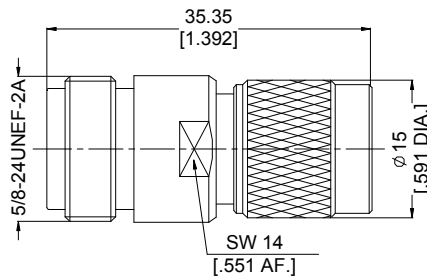

### Adapter plug/jack (male/female)

Part No.	Finish	Type / Type
ANO 511-262-1036	Nickel	N(plug) / QMA(jack)

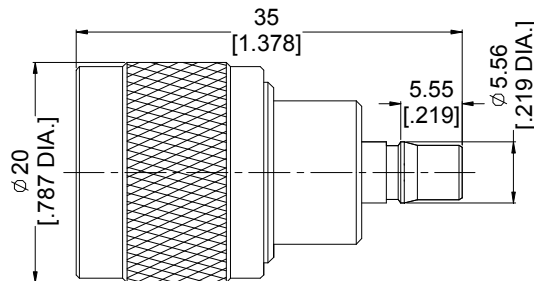

### Adapter plug/jack (male/female)

Part No.	Finish	Type / Type
ANO 512-261-1035	Nickel	N(jack) / QMA(plug)

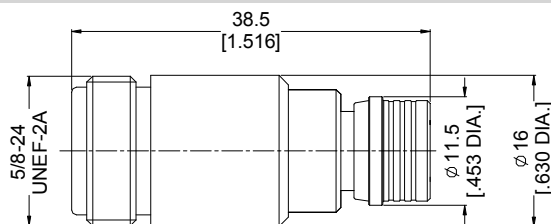

### Adapter plug/jack (male/female)

Part No.	Finish	Type / Type
ANO 511-282-1058	Nickel	N(plug) / Mini-QMA(jack)

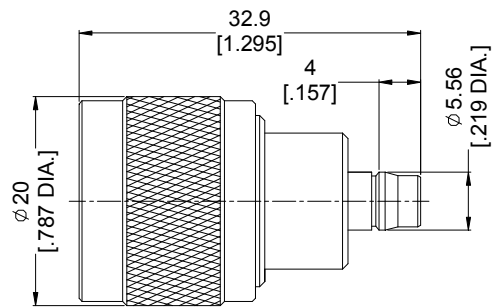

### Adapter plug/jack (male/female)

Part No.	Finish	Type / Type
ANO 512-281-1057	Nickel	N(jack) / Mini-QMA(plug)

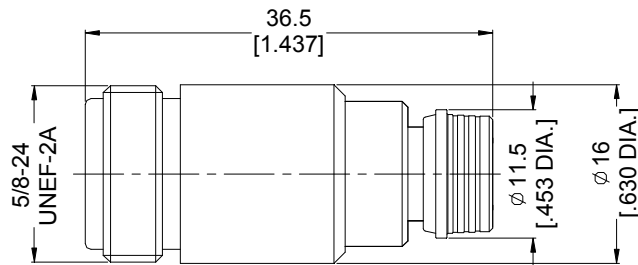

### Adapter plug/jack (male/female)

Part No.	Finish	Type / Type
ANO 511-532-1047	Nickel	N(plug) / HPQN(jack)

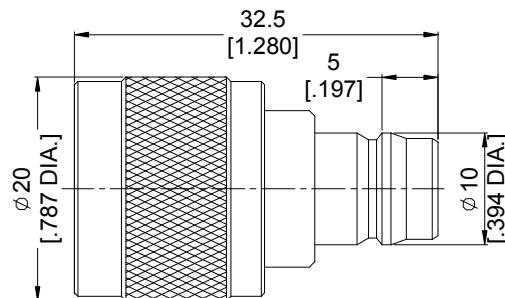

### Adapter plug/jack (male/female)

Part No.	Finish	Type / Type
ANO 512-531-1046	Nickel	N(jack) / HPQN(plug)

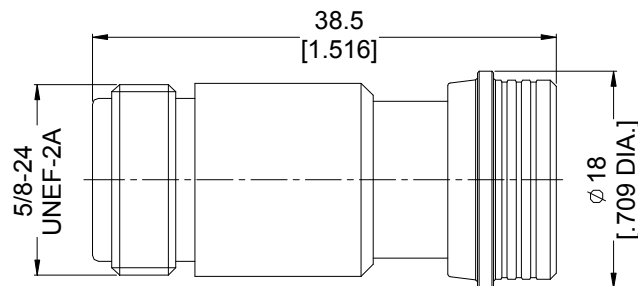

## Termination

### Straight Plugs (male)

Part No.	Finish	Average Power	Peak Power	Frequency
ANO 511-703	Nickel	1W	2500W	0-4 GHz

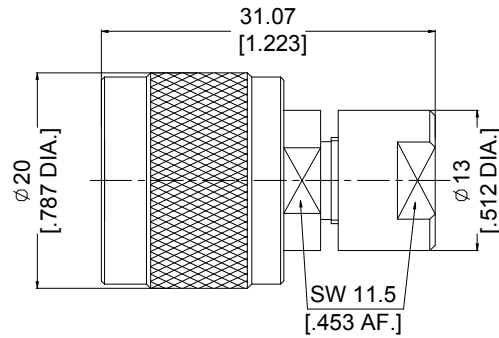

### Straight Plugs (male)

Part No.	Finish	Average Power	Peak Power	Frequency
ANO 511-701	Nickel	5W	1000W	0-6 GHz

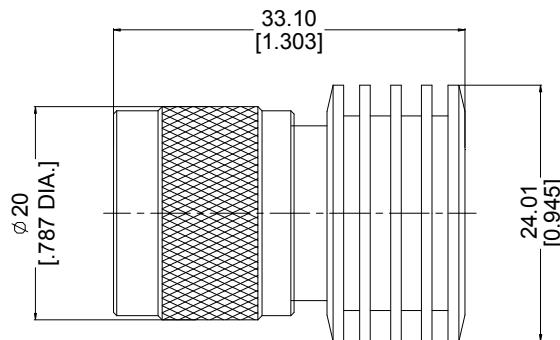

### Straight Plugs (male)

Part No.	Finish	Average Power	Peak Power	Frequency
ANO 511-702	Nickel	25W	500W	0-2 GHz

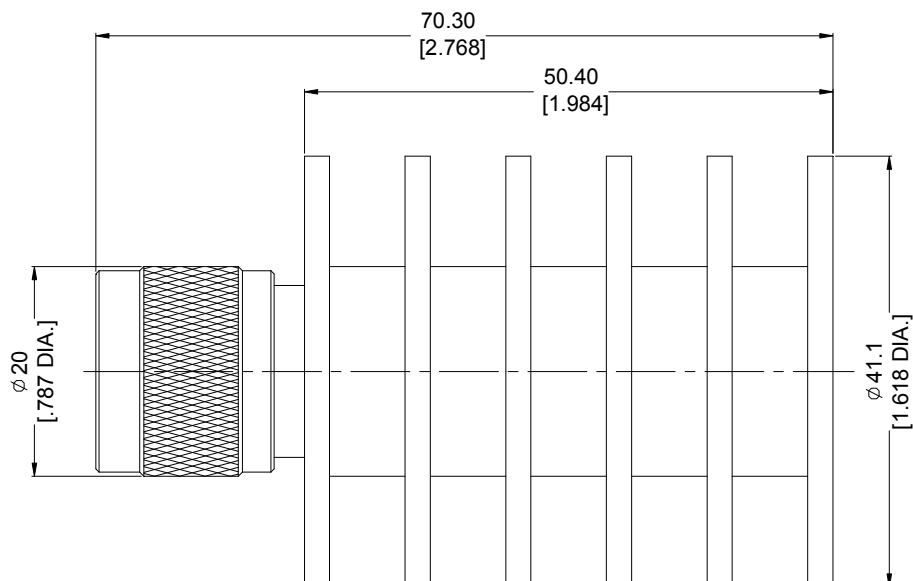

## Assembly Instruction

### AI 01

Part No.	Cable Group (Example)	Stripping Length a
ANO 5111-2034	.141/50 (SMT680-141/RG402)	5.5

①

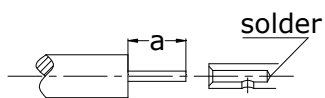

- 1.1 Strip the cable.
- 1.2 Slide on centre contact until it bottoms against cable dielectric.
- 1.3 Solder center contact.
- 1.4 Clean soldering area.

②

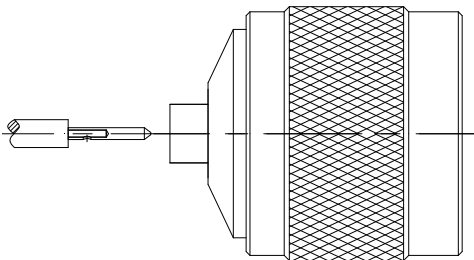

- 2.1 Slide the cable into the body until it bottoms against insulator.

③

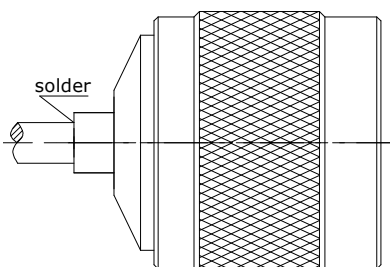

- 3.1 Solder the body onto the cable.
- 3.2 Clean soldering area.

AI 02

Part No.	Cable Group (Example)	Stripping Length		
		a	b	c
ANO 5111-2039	2/50/S (RG78)	2.5	1.8	8.7

①

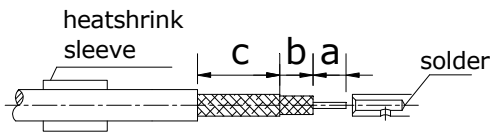

- 1.1 Slide onto the cable the heatshrink sleeve.
- 1.2 Strip the cable.
- 1.3 Slide on center contact until it bottoms against cable dielectrique.
- 1.4 Solder center contact.

②

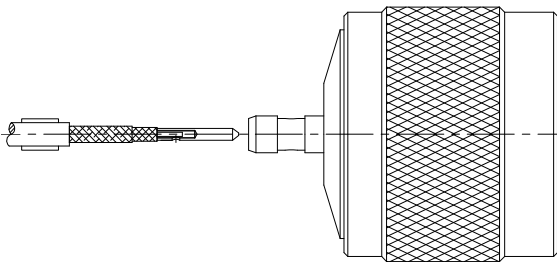

- 2.1 Slide the cable into the body until it bottoms against insulator.

③

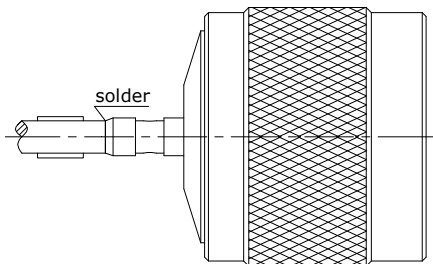

- 3.1 Solder the body onto the cable.

④

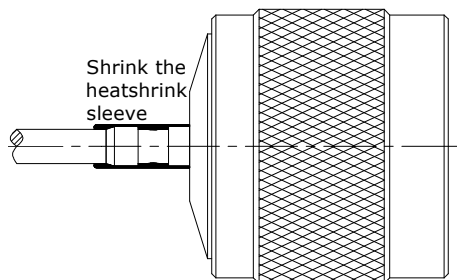

- 4.1 Slide sleeve over soldering area and heatshrink in place.

# AI 03

Part No.	Cable Group (Example)	Stripping Length		
		a	b	c
ANO 5111-2006	2.6/50/S/D (RG316/LMR100)	2.5	3.0	7.0
ANO 5111-2002	5/50/S/D (R68/LMR200)	2.5	3.0	8.0
ANO 5111-2003	6/50 /D (LMR240)	2.5	2.0	9.0
ANO 5111-2028	15/50 /D (LMR600)	6.0	4.0	14.0

①

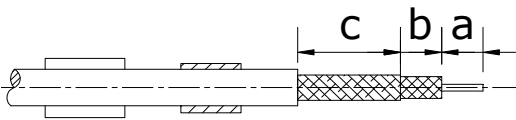

- 1.1 Slide onto the cable the heatshrink sleeve and the ferrule.
- 1.2 Strip the cable.

②

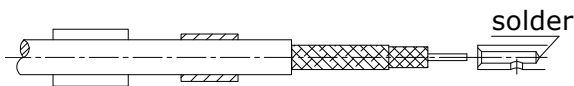

- 2.1 Slide on center contact until it bottoms against cable dielectric.
- 2.2 Solder center contact.

③

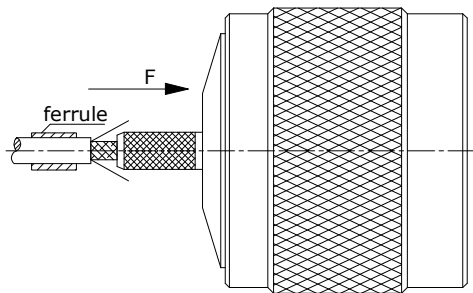

- 3.1 Fan the braid.
- 3.2 Slide the cable into the body until it bottoms against insulator.
- 3.3 Slide the ferrule over the braid.  
(In direction F)

④

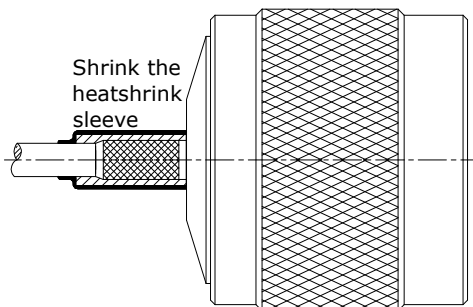

- 4.1 Cut the excess of braid.
- 4.2 Crimp the ferrule.
- 4.3 Slide sleeve over ferrule and heatshrink in place.

## AI 04

Part No.	Cable Group (Example)	Stripping Length		
		a	b	c
ANO 5111-2007	5/50/S/D (R68/LMR195)	5.5	2.0	9.0
ANO 5111-2037	7.5/50 /D (LMR300)	5.5	2.5	10.0
ANO 5112-2038				
ANO 5111-2001	10.5/50 /D (LMR400)	5.4	2.6	10.0
ANO 5112-2025				

①

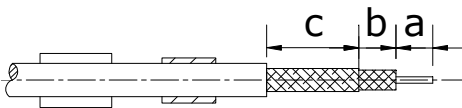

②

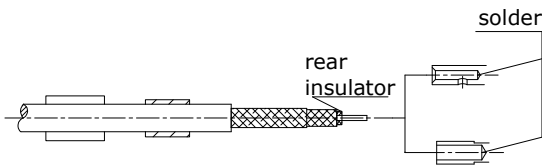

③

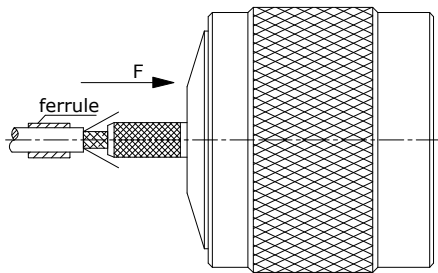

④

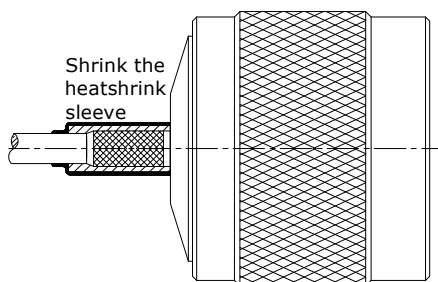

1.1 Slide onto the cable the heatshrink sleeve and the ferrule.

1.2 Strip the cable.

2.1 Slide on rear insulator and center contact.

2.2 Solder center contact.

3.1 Fan the braid.

3.2 Slide the cable into the body until it bottoms against insulator.

3.3 Slide the ferrule over the braid.  
(In direction F)

4.1 Cut the excess of braid.

4.2 Crimp the ferrule.

4.3 Slide sleeve over ferrule and heatshrink in place.

AI 05

Part No.	Cable Group (Example)	Stripping Length		
		a	b	c
ANO 5121-2041	7.5/50 /D (LMR300)	3.0	8.0	9.0

①

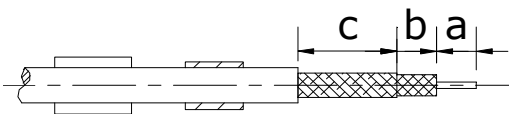

- 1.1 Slide onto the cable the heatshrink sleeve and the ferrule.
- 1.2 Strip the cable.

②

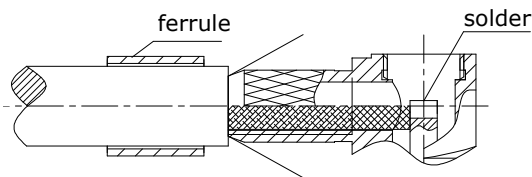

- 2.1 Fan the braid.
- 2.2 Push connector body under the braid.
- 2.3 solder inner conductor.
- 2.4 Slide the ferrule over the braid.

③

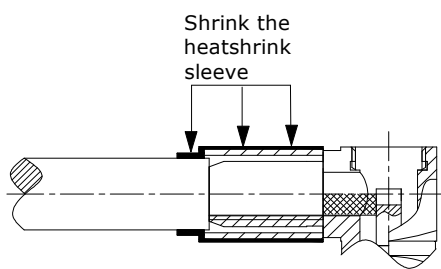

- 3.1 Cut the excess of braid.
- 3.2 Crimp the ferrule.
- 3.3 Slide sleeve over ferrule and heatshrink in place.

④

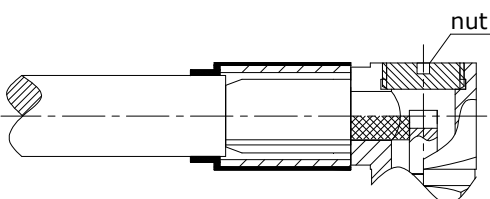

- 4.1 Screw the nut into the body.



AI 06

Part No.	Cable Group (Example)	Stripping Length		
		a	b	c
ANO 5121-2040	10.5/50 /D (LMR400)	6.5	10.0	12.0

①

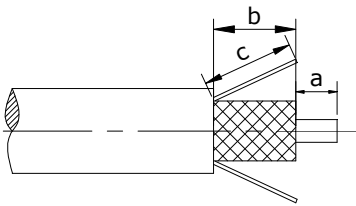

1.1 Strip the cable.

②

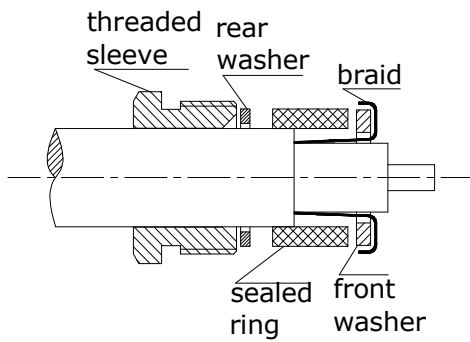

2.1 Slide the threaded sleeve, rear washer, sealed ring and front washer onto the cable.

2.2 Fold back braid and trim off excess of braid.

③

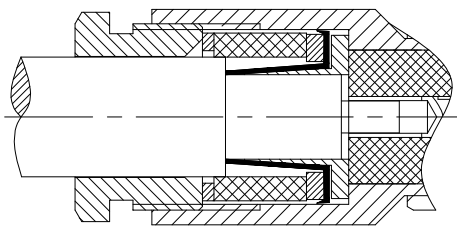

3.1 Screw sub-assembly into the connector body.

AI 07

Part No.	Cable Group (Example)	Stripping Length a
ANO 5112-1018	.083/.085/50 (SMT680-086/RG405)	4.1
ANO 5112-1024		

①

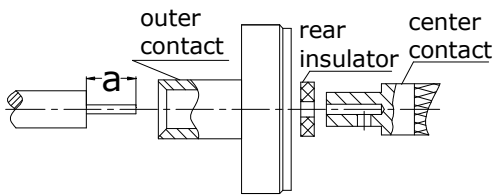

- 1.1 Strip the cable.
- 1.2 Slide onto the cable the outer contact, the rear insulator and the center contact.
- 1.3 Solder center contact.

②

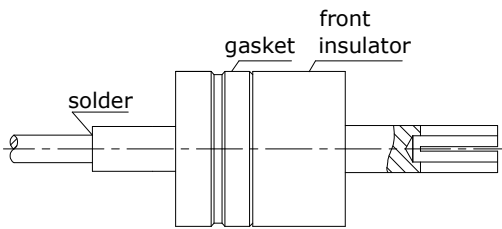

- 2.1 Solder the cable onto the outer contact.
- 2.2 Mount the gasket and the front insulator.

③

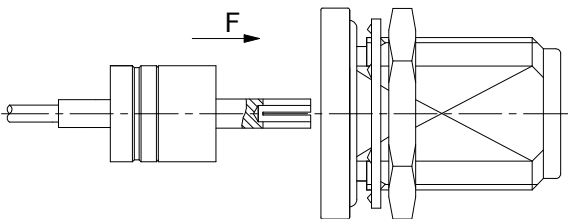

- 3.1 Slide the completed cable into the body.  
(In direction F)

④

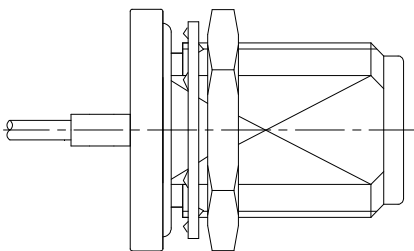

- 4.1 Press the two parts together.

AI 08

Part No.	Cable Group (Example)	Stripping Length		
		a	b	c
ANO 5112-1008	2/50/S (RG78)	3.0	2.0	11.3

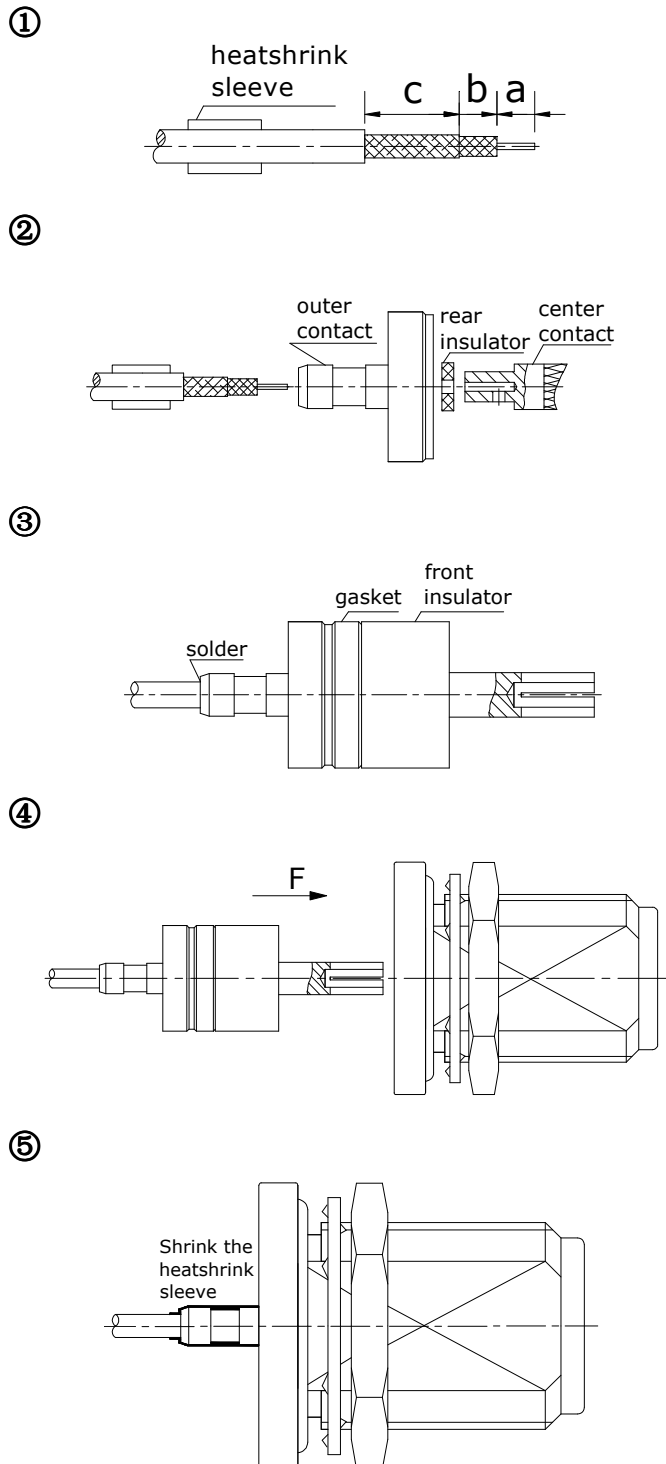

- 1.1 Slide onto the cable the heatshrink sleeve.
- 1.2 Strip the cable.

- 2.1 Slide onto the cable the outer contact, the rear insulator and the center contact.
- 2.2 Solder center contact.

- 3.1 Solder the cable onto the outer contact.
- 3.2 Mount the gasket and the front insulator.

- 4.1 Slide the completed cable into the body.  
(In direction F)
- 4.2 Press the two parts together.

- 5.1 Slide sleeve over soldering area and heatshrink in place.

AI 09

Part No.	Cable Group (Example)	Stripping Length		
		a	b	c
ANO 5112-1010	2.6/50/S/D (RG316/LMR100)	4.0	2.2	7.0
ANO 5112-1009	5/50/S/D (RG58/LMR195)	3.0	4.0	8.5

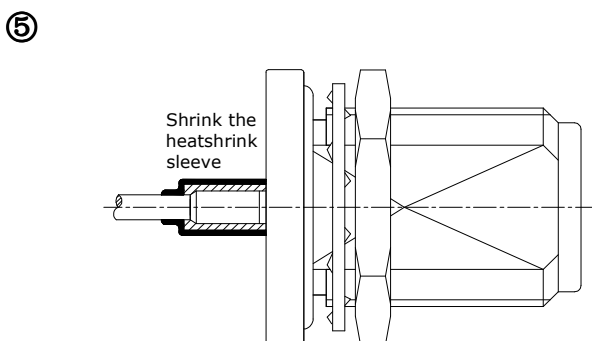
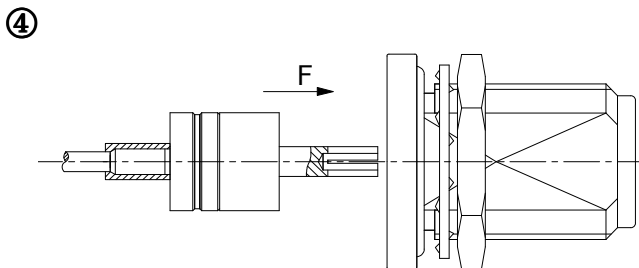
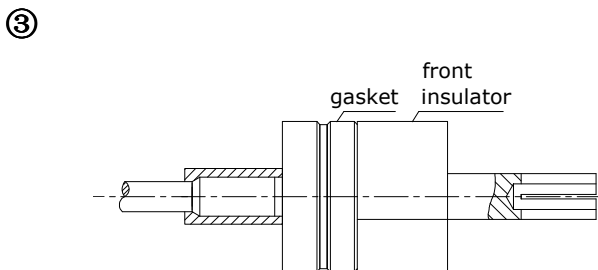
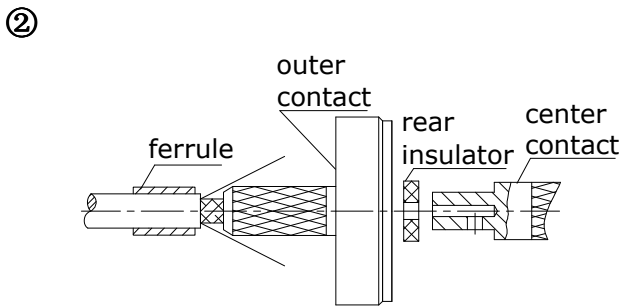
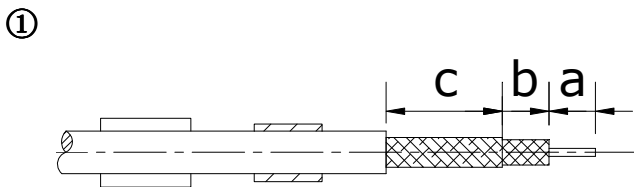

- 1.1 Slide onto the cable the heatshrink sleeve and the ferrule.
- 1.2 Strip the cable.

- 2.1 Fan the braid.
- 2.2 Slide onto the cable the outer contact.
- 2.3 Slide the ferrule over the braid.
- 2.4 Slide onto the cable the rear insulator and the center contact.
- 2.5 Solder center contact.

- 3.1 Cut the excess of braid.
- 3.2 Crimp the ferrule.
- 3.3 Mount the gasket and the front insulator.

- 4.1 Slide the completed cable into the body.  
(In direction F)
- 4.2 Press the two parts together.

- 5.1 Slide sleeve over ferrule and heatshrink in place.